

COMMISSIONING

Selecting the mounting position

IMPORTANT: The CO measurement installation positions should be selected by according to the local standards and regulations. The distribution and number of sensors depend highly on the structural conditions and ventilation.

According to the Finnish building regulations D2 - Instructions for CO measurement in garages:

"At least three control and alarm sensors shall be installed on each level, normally in the vicinity of ramps and driving lanes. The operation of such sensors shall be checked on a regular basis and they shall be calibrated at least once a year. The calibration certificate shall be attached to the guidelines for the use and maintenance of the building."

According to the German building regulations VDI2053 - Car parks' air conditioning:

"A CO monitoring section should not exceed 400 m² of the car park surface. At least one measuring sensor must be assigned to each monitoring section. All safety devices such as air current monitoring, optical and acoustic warnings, CO monitoring system, etc. must be checked annually for proper function. The CO monitoring systems must be calibrated and adjusted, if necessary."

Pay attention also to the following points when selecting the device mounting position:

- Recommended mounting height is 1.5...1.8 m above the floor.

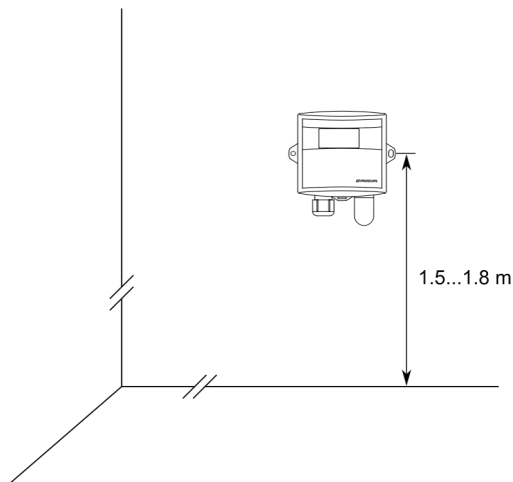

- Do not mount the device in the centre of air flow (air passages, ventilation nozzles).
- Provide adequate space around the device for maintenance and calibration.
- Avoid locations where mechanical damage might be possible.

Wiring



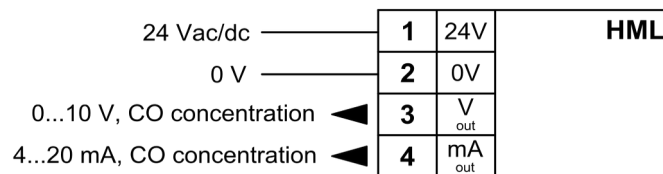

Device wiring and commissioning can only be carried out by qualified professionals. Always make the wirings while the power is switched off.





Jumper settings

Range selection

	0...100 ppm	0...300 ppm *
S1		

* = factory setting

Output selection

	0...10 Vdc *	4...20 mA
S2		

* = factory setting

CALIBRATION

The transmitter calibration interval is one year.

HML can be calibrated by using HMV exchange kit. A new calibration report is delivered with the exchange kit.

Using HMV exchange kit

1. Disconnect the power supply.
2. Remove the cover.
3. Disconnect the display cable (HML-N).
4. Disconnect the cable connector or disconnect the cable leads.

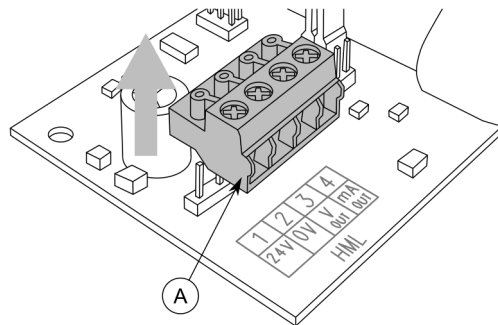

A. Cable connector

5. Unscrew the filter.

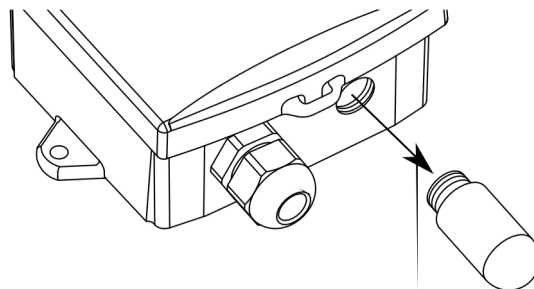

6. Unscrew the circuit board fixing screws.
7. Remove circuit board from the housing.
8. Set the exchange kit jumpers to match the removed board.
9. Place the exchange kit inside the housing and fit the fixing screws.
10. Fit the cable connector or connect the cable leads.
11. Connect the display cable (HML-N).
12. Fit the cover.
13. Connect the power supply.